

! INFO !

Do not charge the battery of the towing vehicle and/or towed vehicle directly via the socket.

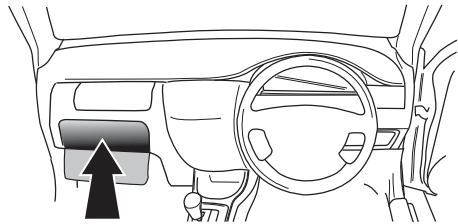

User guide



SPARE PARTS

www.ecs-electronicsuk.co.uk



Partnr.: NI-115-BHU

User Guide

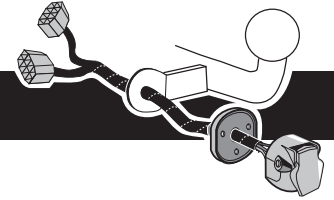

**Nissan Qashqai (J11) 01/2014>>
Nissan X-Trail (T32) 05/2014 >> 08/2022**

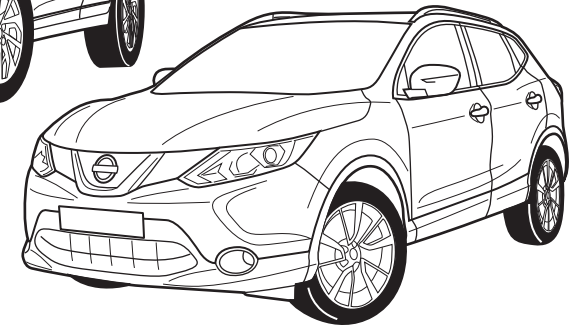
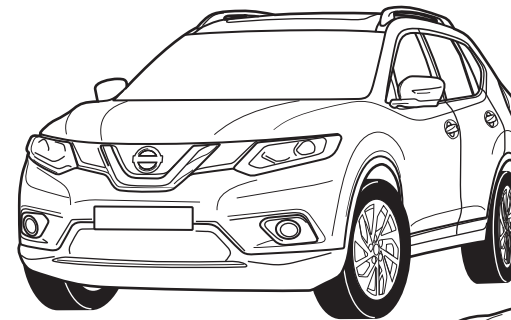

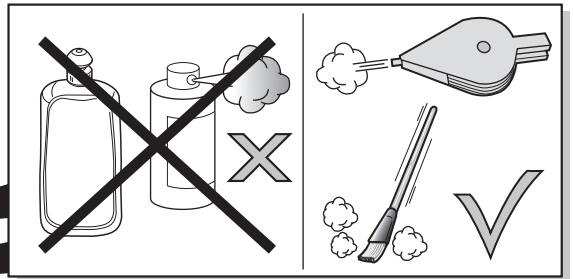
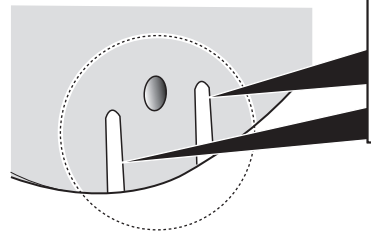
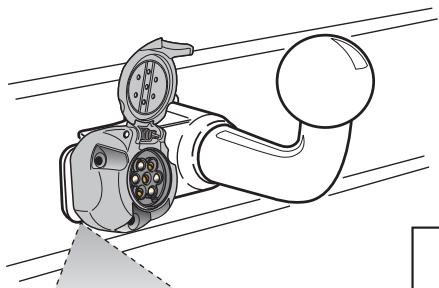
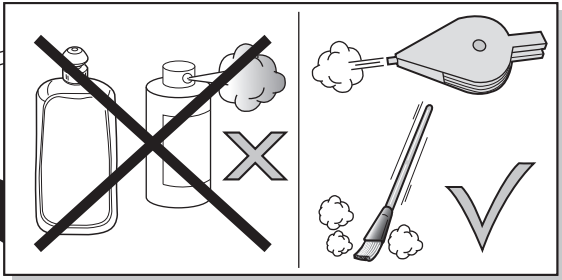
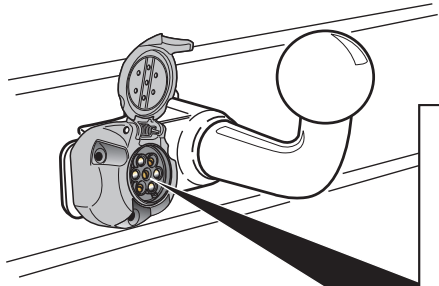
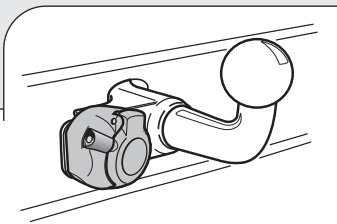

Option 1

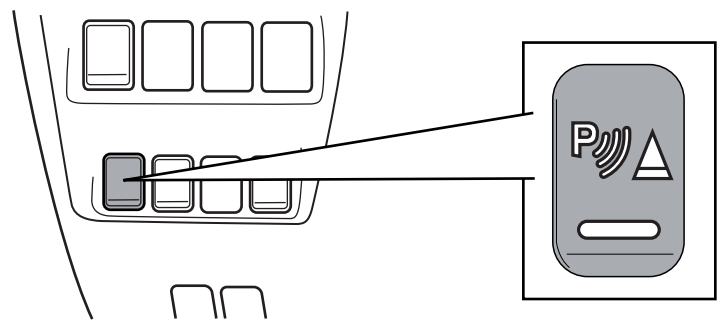
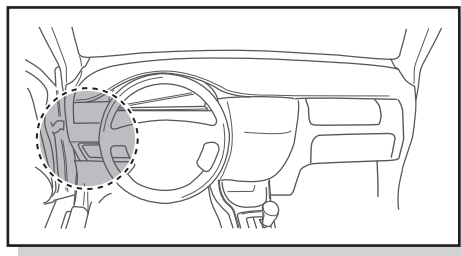
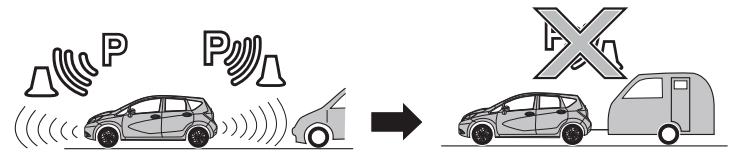

Option 2

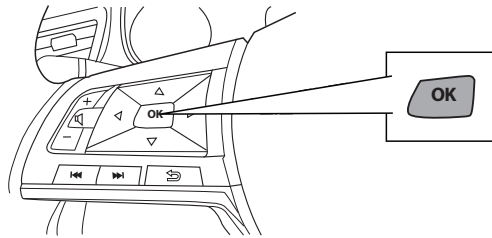
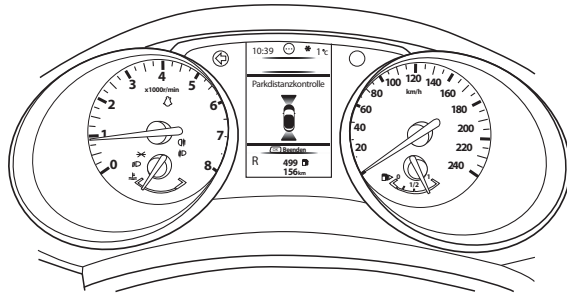
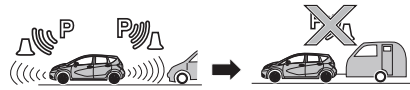

Option 3

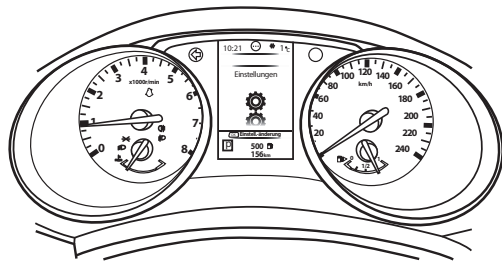
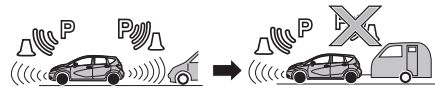

Einstellungen/
settings
↓
Fahrerassistenz/
driver assistance
↓
Parkhilfe/
parking assistant
↓
Sensor Heck ausschalten/
disable rear-sensor ✓

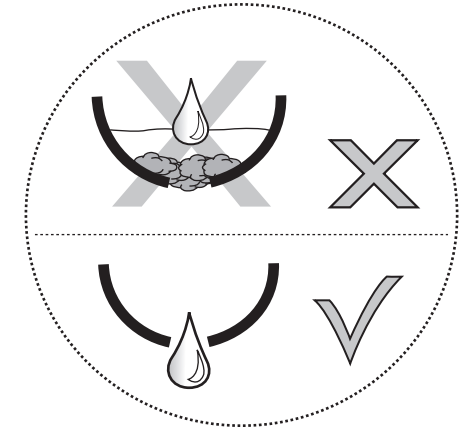
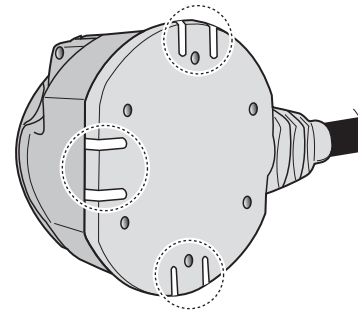
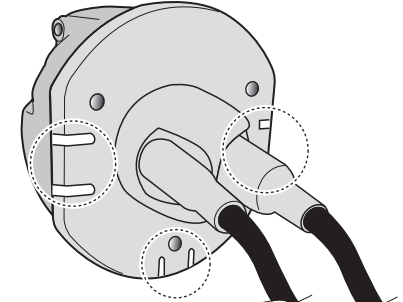
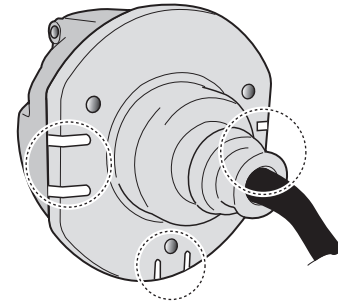
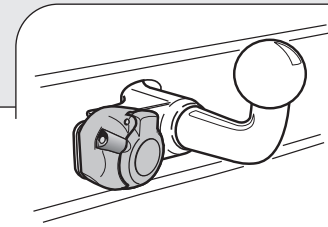

SOCKET CONNECTION

DIN/ISO 1724							
	1/L	2	3/31	4/R	5/58-R	6/54	7/58-L
Pmax	21W	2x21W		21W	52W	3x21W	52W
Colour	Yellow	Blue	White	Green	Brown	Red	Black



In a coupled trailer with working fog lamp, the fog lamp of the vehicle will be switched off, if applicable.

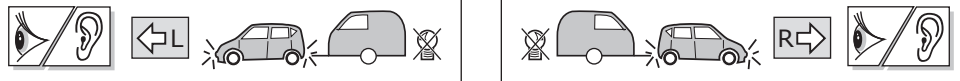

The flashing lights on the trailer are monitored. If one of the indicators of the trailer breaks down, a buzzer will be audible and/or a visual signal will be visible on the dashboard. Check the flashing lights on the trailer.

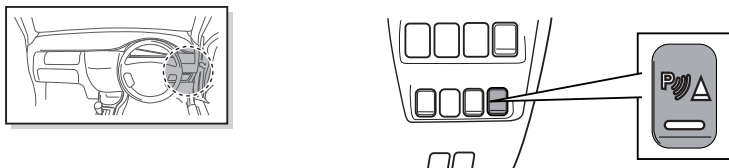
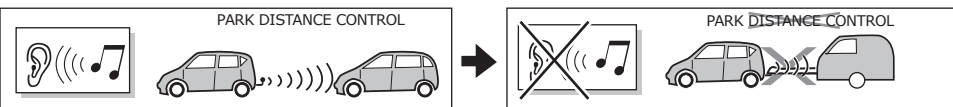

CHANGING THE FUSE

Qashqai

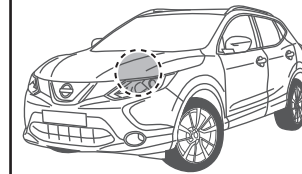

X-Trail

